

RECON™

Revision 4

Digital Video Recorder

Hardware Technical Reference

Revision 1.2

July 2009



Fast Forward Video
1151 Duryea Avenue
Irvine, CA, 92614
USA

Fax: (949) 852-1226
Phone: (949) 852-8404

(This page intentionally blank.)

Contents



CONTENTS	1
OVERVIEW	1
ARCHITECTURE	3
HARDWARE BLOCK DIAGRAM.....	4
SPECIFICATIONS	5
JUMPER AND CONNECTOR LOCATIONS	7
RECON.....	7
CONNECTOR PIN-OUTS	8
POWER	8
IDE HARD DRIVE	8
RS-232.....	9
RS-232 – PORT 0.....	ERROR! BOOKMARK NOT DEFINED.
USB 2.0 FILE ACCESS	ERROR! BOOKMARK NOT DEFINED.
JUMPER BLOCKS	10
GENERAL PURPOSE INPUTS.....	10
AUDIO AND TIME CODE	11
VIDEO INPUT/OUTPUT	11
PIXEL BUS – OPTION J106	12
OPERATION	13
GPI SWITCHES.....	13
LED DETAILS	14
APPENDIX	15
MECHANICAL DIMENSIONS.....	15
ELEVATION	16
REVISION HISTORY.....	16

(This page left blank intentionally)

Overview

Fast Forward Video's Recon™ circuit board is a high quality digital video recording and playback device designed for standalone operation. It was designed as a subsystem for applications requiring video conforming to National Television Standards Committee (NTSC) or Phase Alternation by Line (PAL) specifications. The Recon performs compression and decompression at user-specified ratios as low as 4:1 at 30 frames (60 fields) per second in NTSC. The compression method conforms to the Joint Photographic Experts Group (JPEG) standard. The primary design goal was professional image quality. In addition, the Recon adheres strictly to standards including RS-170A (NTSC) and CCIR-601.

When recording, the Recon converts an analog NTSC or PAL video signal to a component digital format, compresses the digital video signal to a JPEG data stream, and sends the compressed video directly to an ATA/IDE (ATA/ATAPI-4) hard disk. Control of the board is available through a serial port RS232 interface. This port may optionally be configured as RS422/485.

When playing back, the Recon retrieves the compressed video data from an IDE hard disk or compact flash, decodes the JPEG data into digital component video, and converts the digital video to an analog NTSC or PAL video signal.

Composite video and Y/C connectors, decoder, and encoder are included on the Recon. The board's pixel resolution is full bandwidth CCIR-601, which is 720 X 486 in NTSC and 720 X 576 in PAL. Sampling is maintained at 4:2:2.

(This page blank intentionally.)

Architecture

The Recon's primary design goal was to maintain video quality at a level suitable for use in professional video applications. This goal dictated that the sync timing of the output signal must conform strictly to the RS-170 standard (NTSC).

Most important, however, is image quality. Based on subjective evaluation of JPEG compressed video, Fast Forward Video determined that a compression ratio of 5:1 or lower would yield image quality comparable to the Betacam SP™ format, and thus satisfy most professional video users.

To support a sustained data rate at this level, the designers of the Recon included an IDE hard disk controller on the circuit board.

The design includes an on-board 80386EX microprocessor to oversee the hardware and to provide a control interface over the serial ports.

All of the Recon's subsystems share 32 megabytes of dynamic random access memory. This memory is based on a true multi-port architecture that allows direct access by the JPEG codec, the disk controller, and the local 80386EX microprocessor. Direct access to this memory permits each of the subsystems to perform to their maximum potential without concern for DMA contention.

Following is a block diagram of the Recon, Rev. 4.

HARDWARE BLOCK DIAGRAM

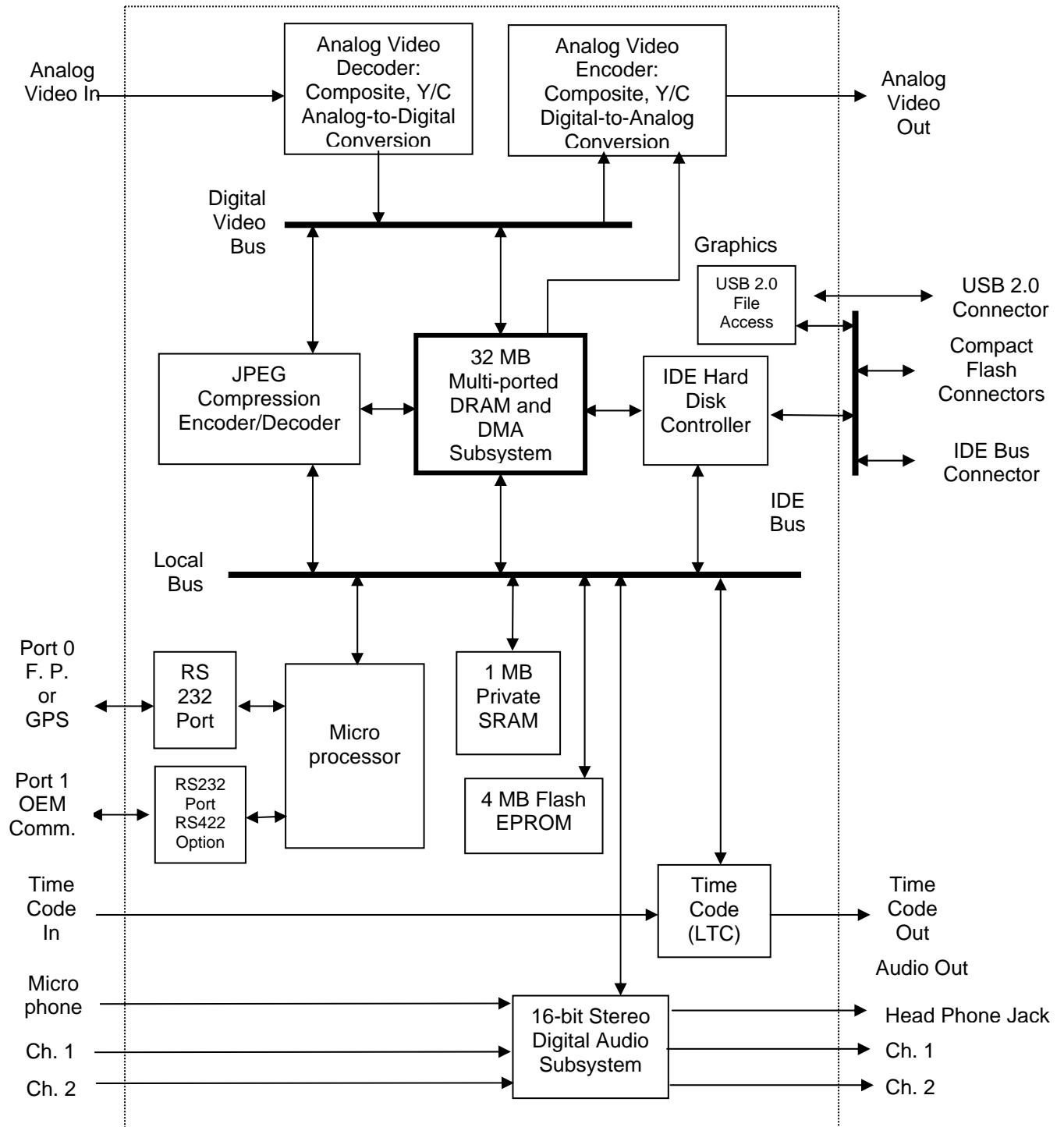

SPECIFICATIONS

RECON CIRCUIT BOARD

Specifications

VIDEO INPUT

Analog Input: Composite and S-Video (Y/C).
Levels: 1.0Vp-p, 75 ohms
Standards: 525/60 (NTSC) or 625/50 (PAL)

VIDEO OUTPUT

Analog Output: Composite and S-Video (Y/C).
Horizontal Resolution: 550 TV lines (at 5:1 compression)
Levels: 1.0Vp-p, 75 ohms
Standards: 525/60 (NTSC) or 625/50 (PAL)
Connections: multi-pin for component (Y/C)

VIDEO INPUT DECODER

Format: Digital 4:2:2 YCrCb
60 fields per second NTSC
50 fields per second PAL

Digital Color Space: YUV
Sampling: 13.5 MHz
Pixel Resolution: 720 x 486 pixels (525/60)
720 x 576 pixels (625/50)

S/N Ratio: 50 dB
Bandwidth: 7 MHz (-3 dB)
Differential Gain: 2%
Differential Phase: 2 deg.
ADC Differential Linearity: +/- 0.7 LSB
ADC Integral Linearity: +/- 1.0 LSB

VIDEO OUTPUT ENCODER

Digital Color Space: Digital 4:2:2 YCrCb
Analog Bandwidth: Y: 6.75 MHz
C: 1.3 MHz

Composite: 4.5 MHz
DAC Resolution: 10 bits x 3
S/N Ratio: 60 dB

VIDEO COMPRESSION

Codec: Zoran
Method: JPEG (Joint Photographic Experts Group)
Compression Ratio: Variable from 4:1 to 20:1.

MEMORY

Multi-port Frame Buffer: 32 MB DRAM
Aggregate Bandwidth: Greater than 45 MB/second

ATAPI/IDE DISK CONTROLLER

Protocol:	ATAPI DMA mode 3
Maximum Data Rate:	16.6 MB/sec
Maximum Hard Drives:	2
Supported Hard Drives:	IBM Travelstar; Fujitsu MHS/MHT Series; Solid State disks available DMA Mode 2 Compact Flash

MICROPROCESSOR

Type:	Intel 80386EX
Clock Speed:	40 MHz
Local ROM/EPROM:	4MB Flash EEPROM
Local SRAM:	1MB 0 wait state

COMMUNICATIONS INTERFACE

RS-232 (RS22/485 optional):	Conforms to Sony "Remote-1 (9 pin)" protocol. 38400 baud, 8 data bits, odd parity, 1 stop bit.
-----------------------------	---

AUDIO SPECIFICATIONS

Resolution:	16 bits
Sampling Rate, FS:	48 Khz
Channels:	2 in, 2 out
Dynamic Range:	90 dB
Total Harmonic Distortion:	-80 dB
Crosstalk:	-80 dB
Interchannel Gain Mismatch:	+/- 0.5 dB
Input Voltage:	1 VRMS nominal, 3V p-p max
Input Impedance:	35k ohms
Input Programmable Gain Span:	22.5 dB
Full Scale Output Voltage:	1 VRMS
Output Impedance:	10K ohms
Output Attenuation Range:	80 dB

SOFTWARE

Optional:	Recon control interface. Runs on Windows 9x/2000, and XP.
-----------	--

GENERAL

Size:	2.8" W x 3.9" L x 0.6" D
Power Consumption:	3 watts not including hard disk Requires regulated input of +5V.
Warranty:	1 year

Specifications subject to change without notice

Jumper and Connector Locations

RECON

Part Number 309-PC023-4, Revision B

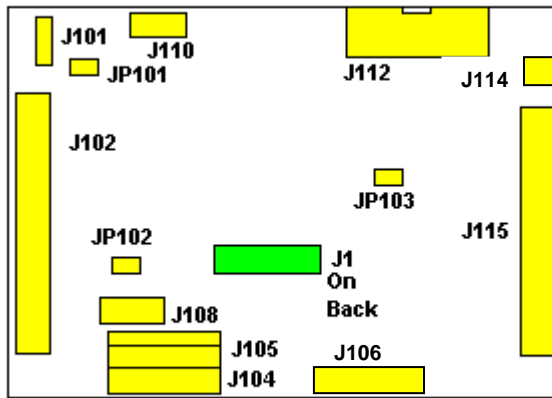

LEGEND		
REF #	FUNCTIONAL DESCRIPTION	MFR. P/N OR DESCRIPTION
J101	POWER	MOLEX P/N 70553-0002
J102	ATA / IDE HARD DRIVE	STD. 2-Row, 44 pin IDE – 2mm
J104	RS-232 PORT	STD. 2-Row, 10 PIN IDE
J105	RS-422 PORT (OPTION)	STD. 2-Row, 10 PIN IDE
J106	PIXEL BUS (OPTION)	SAMTEC P/N SFM-110-L2-S-D-L-C
J108	RS-232 PORT (OPTION)	MOLEX P/N 53398-0490
J109	COMPACT FLASH (OPTION)	CF, Type I or Type II
J110	GPI PORT	STD. SINGLE ROW, 8 PIN IDE
J112	AUDIO AND TIME CODE INPUT/OUTPUT	STD. 2-Row, 14 PIN IDE
J114	USB	MINI USB 2.0
J115	VIDEO INPUT/OUTPUT	STD. 2-Row, 20 PIN IDE, RIGHT ANGLE
JP101	MICROPROCESSOR RESET	STD. 2 PIN IDE
JP102	FIRMWARE UPDATE JUMPER	STD. 2 PIN IDE
JP103	BOOT CODE WRITE ENABLE JUMPER	STD. 2 PIN IDE
J1	MICROPROCESSOR BUS EXPANSION	SAMTEC P/N SFM-125-L2-S-D-L

CONNECTOR PIN - OUTS

POWER

Connector Pin-Outs

POWER J101	
Pin	Function
1	Ground
2	Ground
3	+5 volts in

IDE HARD DRIVE J102			
Pin	Function	Pin	Function
1	RESET	23	DIOW
2	GROUND	24	GROUND
3	DD07	25	DIOR
4	DD08	26	GROUND
5	DD06	27	IORDY
6	DD09	28	CSEL (GROUND)
7	DD05	29	DMACK
8	DD10	30	GROUND
9	DD04	31	INTRQ
10	DD11	32	Not connected
11	DD03	33	DA1
12	DD12	34	PDIAG (not connected)
13	DD02	35	DA0
14	DD13	36	DA2
15	DD01	37	CS0
16	DD14	38	CS1
17	DD00	39	DASP (not connected)
18	DD15	40	GROUND
19	GROUND	41	+ 5V
20	Key pin (N/C)	42	+ 5V
21	DMARQ	43	GROUND
22	GROUND	44	Not Connected

RS-232 J104	
Pin	Function
1	Not connected
2	DTR
3	Transmit Data (TX)
4	Not connected
5	Receive Data (RX)
6	Not connected
7	Not connected
8	Not connected
9	Ground
10	Not connected

RS-422 (OPTIONAL) J105	
Pin	Function
1	Ground
2	Ground
3	Transmit Data (-)
4	Transmit Data (+)
5	Receive Data (+)
6	Receive Data (-)
7	Ground
8	Ground
9	Not used
10	Not used

USB 2.0 FILE ACCESS J114	
Pin	Function
1	USBPWRV
2	USBD-
3	USBD+
4	
5	Ground

RS-232 – PORT 0 J108	
Pin	Function
1	Ground
2	DTR
3	Receive data (RX)
4	Transmit data (TX)

CONNECTOR PIN - OUTS

JUMPER BLOCKS

JUMPER BLOCKS	
Install jumpers or short pins to force the following behavior when applying power to the board:	
	Behavior
JP101	Short momentarily for hardware RESET.
JP102	Forces board into firmware update mode at 38400 baud, 8 data bits, ODD parity, 2 stop bits
JP103	Enables boot code write to Flash. This is not usually necessary in the field.

GENERAL PURPOSE INPUTS			
J110 – 8 pin			
Pin	GPI	Function	Source/Sink (I)
1		LED 1 Output	8 mA max.
2		LED 2 Output	8 mA max.
3	1	● Record	16 mA min.
4	2	■ Stop	8 mA min.
5	3	► Play	8 mA min.
6	4	◀◀ Left Arrow	8 mA min.
7	5	▶▶ Right Arrow	8 mA min.
8		Ground	8 mA min.

AUDIO AND TIME CODE J112	
Pin	Function
1	Ground
2	Left channel - in
3	Ground
4	Right channel - in
5	Ground
6	Left channel - out
7	Ground
8	Right channel - out
9	Ground
10	
11	Ground
12	Time Code In
13	Ground
14	Time Code Out

VIDEO INPUT/OUTPUT J115	
Pin	Function
1	Reference video in
2	Ground
3	C (chroma) in
4	Ground
5	Not Connected
6	Ground
7	Not Connected
8	Ground
9	Y (luminance) in
10	Ground
11	Composite video in
12	Ground
13	C (chroma) out
14	Ground
15	Composite out #2
16	Ground
17	Y (luminance)
18	Ground
19	Composite video out
20	Ground

CONNECTOR PIN-OUTS

PIXEL BUS – OPTION J106

PIXEL BUS – OPTION J106			
+5 Vdc	1	2	+3 Vdc
HREF	3	4	VREF
Pixel Bus Bit 0	5	6	Pixel Bus Bit 1
Pixel Bus Bit 2	7	8	Pixel Bus Bit 3
Pixel Bus Bit 4	9	10	Pixel Bus Bit 5
Pixel Bus Bit 6	11	12	Pixel Bus Bit 7
SCL	13	14	DC Coupled Composite Sync In
SDA	15	16	No Connection
No Connection	17	18	Ground
27 MHz	19	20	Ground

Operation

There are five level sensitive, fully de-bounced inputs available for user control. These inputs are suitable to be connected directly to off-the-shelf pushbuttons. The action described below occurs immediately upon contact closure, that is, when the input is shorted to ground.

GPI SWITCHES

Record	●	When recording, all other keys are disabled EXCEPT the key combination to stop recording.
Stop recording	■ + ●	
Play	▶	Key has no effect when in pass-through mode. To switch from pass-through mode to playback mode, you must cue to a recorded frame using either the ◀◀ or ▶▶ key.
Pause playback	■	
Cue to first frame (beginning) of previous clip	◀◀	
Cue to first frame of next clip	▶▶	
Cue to first recorded frame	◀◀ for 1 second	Press and hold the ◀◀ key.
Cue to last recorded frame	▶▶ for 1 second	Press and hold the ▶▶ key.
Step forward one frame	■ + ▶▶	Press the ■ key first, then touch the ▶▶ key. When both keys are held down, advances at a rate of about 5 frames per second. Advances one field or frame according to the configured slow motion mode.
Step back one frame	■ + ◀◀	Press the ■ key first, then touch the ◀◀ key. When both keys are held down, steps back at a rate of about 5 frames per second.
Scan forward	▶ + ▶▶	Press and hold the ▶ key first, then touch the ▶▶ key. Successive presses of this combination alternate between 5X and 30X play speed.
Scan reverse	▶ + ◀◀	Press and hold the ▶ key first, then touch the ◀◀ key. Successive presses of this combination alternate between 5X and 30X play speed.
Switch from play mode to pass-through mode	■ + ●	Press the ■ key first, then touch the ● key.
Delete all video & Format disk - (formats based on Configuration Items C0 and C1)	◀◀ + ▶▶ + ●	Press and hold first the ◀◀ key, then the ▶▶ key, then ●. Release all three. Both LEDs flash requesting confirmation of delete. Press ● for 5 seconds. When LED indicates Pass-Thru, Delete is complete.

OPERATION

LED DETAILS

LED DETAILS

The LED outputs supply a maximum of 8mA current. The LEDs should be connected between the output and GND. The LED functions are indicated in the table below:

MODE	ACTION	LED	DISPLAY
Pass-Thru	Pause	2	Single short blink per second.
Pass-Thru	Record	2	LED On
Playback	Pause	1	Single short blink per second.
Playback	Play Normal Speed	1	LED On
Playback	Forward Scan	1	Blinks with Short, Short, Long, Short sequence
Playback	Reverse Scan	1	Blinks with Short, Long, Short sequence
Confirm Video Delete		1 & 2	LEDs alternate short blinks.

Appendix

MECHANICAL DIMENSIONS

Note that there are a few connectors that are not documented. This is intentional, since officially these connectors are not supported and are not guaranteed to remain unchanged from one revision to another. We can provide locations on request, but the customer must understand that they use them at their own risk.

Recon Digital Video Recorder
 Part #309-PC023-4 Rev B
 Fast Forward Video
 (949) 852-8404

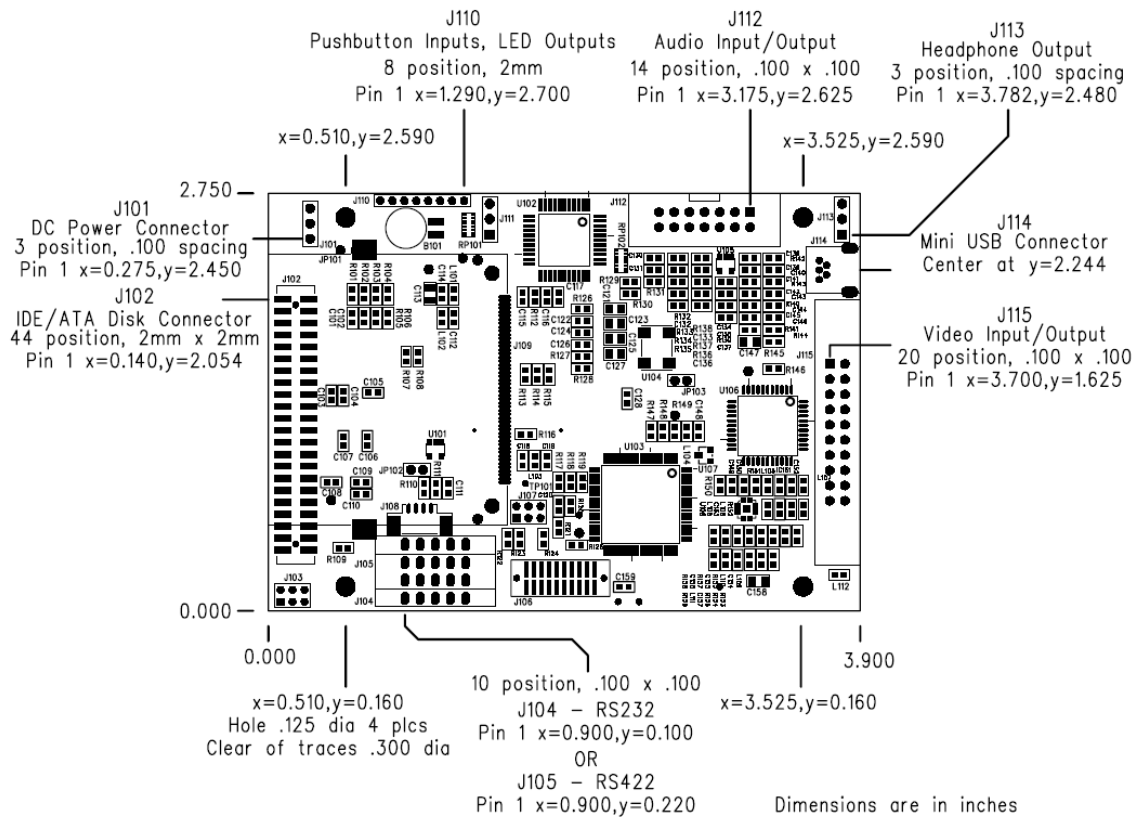

APPENDIX

ELEVATION

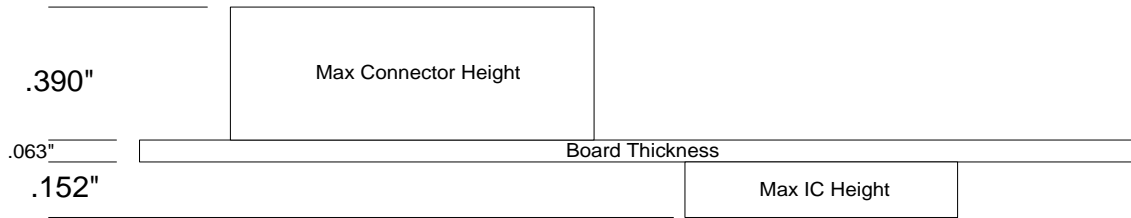

REVISION HISTORY

- Rev. 1.0 – Initial Release
- Rev. 1.1 – Specification/Connection Change